

The full range of Schiedel Rite-Vent products



Flexible Liners

For relining existing chimneys to take gas, oil, wood, multi-fuel appliances and open fires. Single skin Wonderflex and Triplelock for gas and oil (28 sec). Twin skin TecnoFlex (Turboflex Plus) for oil, wood, multi-fuel and open fires. 80-400mm diameter range.



Flue Boxes

For installing gas fires and back boilers. Connection to single and twin skin flexible liners, B Vent, ICS or ICID. Fast fix spigot for flex connection avoids much of the building work. Single skin and twin skin air-insulated versions.



K Vent

Twin wall insulated venting system for oil (28 sec) and gas appliances. Residential and small commercial applications. 100-150mm internal diameters. Oil appliances up to 45kW output. Gas appliances up to 60kW input. Interfits with B Vent gas vent.



ICS

Twin wall insulated chimney system for gas, oil, wood and multi-fuel appliances and open hearths. Residential and commercial applications. 80-705mm internal diameters. For atmospheric, condensing and pressure appliances. Wet or dry flue and chimney operating conditions.



ICID

Quick assembly twin wall insulated chimney system for gas, oil, wood and multi-fuel appliances and open hearths. Residential and small commercial applications. 125-300mm internal diameters. Quick assembly twist-lock joint. For atmospheric appliances and Class 1 chimneys.



B Vent

Twin wall gas venting system. Residential & small commercial applications. 75-150mm internal diameters. Gas appliances up to 60kW input.



Prima

Prima Plus 1mm for domestic multi fuel stoves. Prima Plus for large residential and commercial condensing gas and oil appliances and chimney relining.

for further details
www.schiedelrite-vent.co.uk
www.schiedel.ie



Schiedel Rite-Vent
Crowther Estate
Washington
Tyne & Wear NE38 0AQ
Tel. +44 (0)191 416 1150
Fax. +44 (0)191 415 1263
sales@schiedelrite-vent.co.uk
www.schiedelrite-vent.co.uk

Schiedel Chimney Systems
Carrickmacross
Co. Monaghan
Ireland
Tel. +353 (0)42 966 1256
Fax. +353 (0)42 966 2494
office@schiedel.ie
www.schiedel.ie



ICS - Installation guidelines

- 80 - 300mm internal diameter
- Twin wall insulated chimney system for gas, oil, wood and multi-fuel
- ICS Plus for condensing & ICS for non-condensing applications

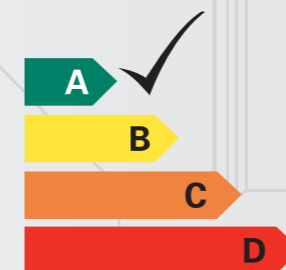

ISSUE 1 - JUNE 2008

Application

ICS is a twin wall insulated chimney system for use on stoves, open fires, residential and small commercial multi fuel appliances, with continuous operating temperatures up to 450°C and short firing up to 550°C.

ICS Plus ICS is converted into ICS Plus by adding a gasket to each component. This creates a twin wall insulated chimney system designed for the new generation of condensing gas and oil appliances, with continuous operating temperatures up to 160°C, short firing up to 200°C, and positive pressure up to 200pa at the appliance outlet.

Other ICS Ranges. For larger commercial and industrial applications of ICS in diameters 355mm to 705mm please refer to our separate sales brochure. For higher pressure applications up to 5000Pa e.g. generators, combustion and process equipment, please see the commercial brochure.

Product Description

ICS

- Simple push-fit jointing system, secured by locking band.
- Advanced corrosion resistant design and construction uses laser welded 316L stainless steel inner liners and 304 stainless steel case. The only stainless steel system to have passed the internationally recognised GASTEC corrosion test.
- The jointing system increases rigidity and ensures easy draindown of any condensate in the flue.
- Capillary break prevents moisture being drawn through the joint.
- Because of the sleeve joint, the insulation in the pipe is able to be continuous the length of the system ensuring no hot spots.
- The 25mm high efficiency Superwool™ blanket maintains flue gas temperature, maximising efficiency, improving flue draught on start up and minimising condensation.
- Low external case temperature.
- The assembly method allows the inner liner to expand and contract with temperature at the female end. The flue can withstand the temperatures of a soot fire without losing the integrity of the joints.
- Generous lead-in edges on liner and case for ease of jointing.

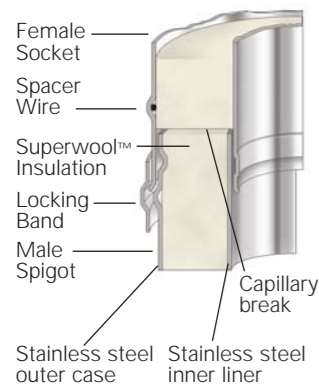

ICS Plus

ICS Plus for condensing appliances is created by adding a gasket that can maintain positive pressure up to 200Pa. All the design and construction benefits of ICS apply.

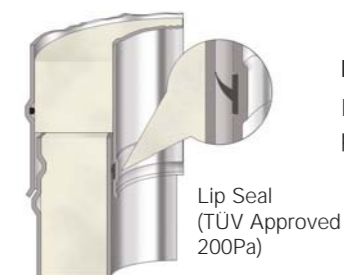

Approvals



ICS is CE Certified to EN1856-1. Additionally, kitemarked to BS4543 Parts 2 & 3 in diameters 80, 100, 130, 150, 180 and 200mm for gas, oil, and solid fuel applications and is manufactured under the stringent requirements of BS EN ISO 9001:2000 Quality management scheme. ICS also has a 4 Hour fire-rating issued by a NAMAS approved test house in accordance with BS476 Part 20. The liner has corrosion certification from Gastec, MPA and TÜV. ICS is also listed by HETAS as a chimney suitable for solid fuel.

Corrosion Resistance

Chimneys are subject to significant corrosion attack by flue gas condensates, particularly from solid fuel and condensing appliances. ICS is specifically designed and manufactured to resist this corrosion. It is the only stainless steel chimney system in the world to have passed the internationally recognised Gastec corrosion test.

Flue Size Selection Guide

The chimney size should be as recommended by the appliance manufacturer. Where there is a requirement for a flue diameter smaller than the appliance spigot, then the operational requirements of the appliance and the configuration of the flue must satisfy the flue sizing requirements. Covered in the following standards: EN 18160-1 (General Requirements), EN 13384-1 (Single Appliance Sizing), EN 13384-3 (Sizing Tables & Graphs) and EN13084 (Industrial Chimneys). For more information contact the installer helpline. The information and sizes below are provided as a nominal guide only. Flue sizing for appliances, particularly commercial/industrial applications, will vary depending on siting details and appliance manufacturer's instructions and design criteria. These will override the sizing guide and reference must be made to appliance manufacture. For Inglenook and non-standard openings, the diameter of the flue must be at least 15% of the cross sectional area of the fireplace opening.

	80 mm	100 mm	130 mm	150 mm	180 - 400mm
Gas - Atmospheric Boiler					
Input up to 25kw		•			
Input 25kw to 40kw			•		
Input 40kw to 60kw				•	
Gas - Commercial/Ind. Boiler					
Input 50kw to 70kw					•2
Gas Fires					
'Radiant' to BS7977-1 2002			•		
'Inset' to BS7977-1 2002			•1		•1
'Backboiler' to BS7977-2 2003			•		
Gas Water Heaters					
Input up to 25kw	•	•			
Input 25kw to 55kw			•		
Input 55kw to 60kw				•	
Input over to 60kw					•2
Gas Warm Air Unit					
Input up to 18kw		•			
Input 18kw to 35kw			•		
Input 35kw to 60kw				•	
Input over to 60kw					•2
Gas Stove/Cooker		•2	•2	•2	
Kerosene (28sec Class C2)					
Heating Boiler					
Output up to 25kw		•			
Output 25kw to 45kw			•		
Output 45kw to 70kw				•	
Kerosene Stove/Cooker		•3	•3	•3	
Kerosene Water Heater					
Input up to 41kw				•	
Kerosene Visual Effect Stove					
Output up to 17kw		•3	•3		

Technical Data

	ICS	ICS Plus
Fuel	Gas, oil, wood, coal	Gas, oil
Firing Temp	450° C	160° C
Short Firing Temp	550° C	200° C
Thermal Shock	1000° C	-
Mode of Operation	Zero & negative pressure	Positive pressure
Pressure Capabilities	40Pa	200Pa
Fire Rating	4 Hour Fire Rating to BS 476 Part 20	
Outer Case	304 : 1.4301 : X5CrNi 18-10	
Outer Case Thickness	0.6mm	
Seam	Laser or inert gas welded	
Liner	316L : 1.4404 : X2CrNiMo 17-12-2	
Liner Thickness (mm)	0.5mm	
Seam	Laser or inert gas welded	
Insulation	High performance mineral fibre	
Insulation Thickness	25mm (50, 75, 100 available)	
Average Thermal Resistance (200°C)	0.508m ² kw	

	100 mm	130 mm	150 mm	180 mm	200 mm	230 mm	250 - 400mm
Gas Boiler - Forced Draught							
Input up to 25kw	•						
Input 25kw to 45kw		•					
Input 45kw to 50kw			•				
Input 50kw to 75kw				•			
Input 75kw to 100kw					•		
Input over to 100kw						•	•2
Gas Fires							
'Inset' to BS7977-1 2002				•1			
'Decorative' BSEN 509:2000				•			
Gas Oil (35sec Class D)							
Heating Boiler							
Output up to 25kw	•						
Output 25kw to 45kw		•					
Output 45kw to 70kw			•				
Output 70kw to 100kw				•			
Output over 100kw					•3	•3	•3
Solid Fuel							
Heating Boiler							
Input up to 20kw			•S	•SC			
Input 20kw to 30kw				•S	•SC	•SC	
Input 30kw to 60kw					•SC	•SC	•SC
Open Fires (standard opening)							
500mm x 550mm					•		
					200min		
Avant Garde Feature Open Fires							•4
Room Heaters			•S				
Wood burning stoves and cookers							
Use only seasoned wood.				•	200min		
Inglenook/ non-standard opening							
Flue size dependant on cross-sectional area of fireplace opening.							•
							230min

Notes: 1 Subject to appliance manufacturer's testing criteria. 2 Subject to manufacturer's input rating and chimney height. 3 Subject to manufacturer's output rating and chimney height. 4 Min 300mm depending on opening, chimney size and height. S Smokeless fuel only. SC Smokeless fuel or coal.

System Design

Outlet Siting

Flue terminations for solid fuel & oil are subject to BS7566 Parts 1, 2, 3 and 4. Figure A illustrates recommendations for the most commonly encountered outlet terminations. Flue terminations for gas in domestic situations are governed by the new BS5440-1 2000 Section 4.2. Figure B illustrates recommendations for the most common siting situations encountered. Adjacent taller structures may require increased height. The minimum flue projection through the roof is 600mm to the underside of the terminal.

Location of outlet

Figure A

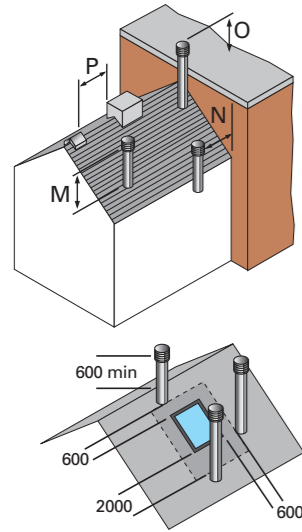
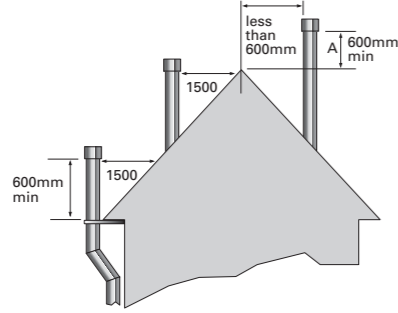

Figure B

BS 5440-1
Gas Termination



	Location of outlet	Pressure jet burner	Vapourising burner	Solid fuel
M	Above the highest point of an intersection with the roof	600mm	1000mm	1000mm
N	From a structure to the side of the terminal	750mm	2300mm	2300mm
O	Above a vertical structure which is less than 750mm (pressure jet burner) or 2300mm (vapourising burner) horizontally from the side of the terminal	600mm	1000mm	1000mm
P	From a ridge to a vertical structure on the roof	1500mm	should not be used	should not be used

Figure C

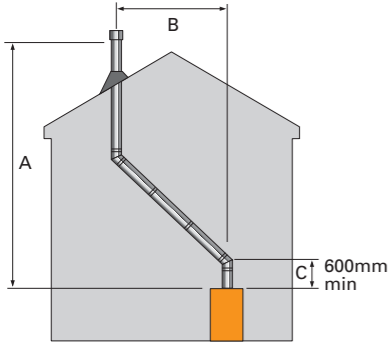

Flue Routing

The chimney should remain as straight as possible through its vertical run to assist flow. Should it be necessary to offset a chimney run the following guidelines should be adhered to:

Gas: An offset no greater than 45° to the vertical, with a run between the bends (B) not exceeding half the overall height of the chimney (A) should be maintained. See Figure C.

Oil - Solid Fuel: An offset no greater than 45° to the vertical, with a run between the bends not exceeding 20% of the overall height of the chimney should be maintained. In both instances a maximum of two bends in any one chimney run should be used. A vertical rise of 600mm should be allowed immediately above the appliance before any offsets. Reference for both guidelines can be found in the Building Regulations Doc J and relevant British Standards on installations.

Terminal Types

For solid fuel appliances, BS7566 Parts 1, 2, 3 and 4 recommends use of an open terminal for chimneys up to 200mm diameter. Rain ingress should not be significant, but drain components can be fitted. Above 200mm a covered terminal can be used, and for all oil and gas installations. Mesh carries the risk of sooting and requires regular cleaning to avoid blockage particularly with oil and solid fuel.

Provision for sweeping, cleaning and maintenance

Provision should be made for inspecting and cleaning the chimney. This is particularly important on solid fuel applications. It is recommended that chimneys serving solid fuel appliances be swept as frequently as necessary but at least twice a year. Choose an access component suitable for your installation unless cleaning/inspection can be done through the appliance.

Room Ventilation

The room carrying the appliance should have an air vent either direct to an external air source or vented into a room that has an external vent direct to an air source. This is required to provide adequate air supply to allow the appliance and flue to operate efficiently. These requirements are specified in the Building Regulations (Document J) also by CIBSE and BS5440.

Commercial Installations

Schiedel Rite Vent can provide a full design & flue sizing advice service for commercial installations. The ICS range contains all the required components for commercial use including time-saving telescopic header tees for increasingly popular multi-boiler installations.

Support Components

The weight of a chimney system is considerable and requires independent support. Minimal weight should be taken by the appliance. A wall support at the base of the stack will support up to 10m of chimney, or in an inverted position, up to 15m. Wall supports can then be used as an intermediate support every 10m thereafter.

Alternatively, on internal systems the weight is held by using a support plate and clamp fixed on top of the first floor/ceiling joist. A Firestop plate is also required fixed to the ceiling below. In a domestic house, when passing through the second floor the only requirement is two firestop plates because the system is adequately supported at first floor level.

External installations

- Twin wall ICS 25mm

Covered by designations:
EN 1856-1 T450 N1 W V2 L50050 G50
EN 1856-1 T450 N1 D V3 L50050 G50

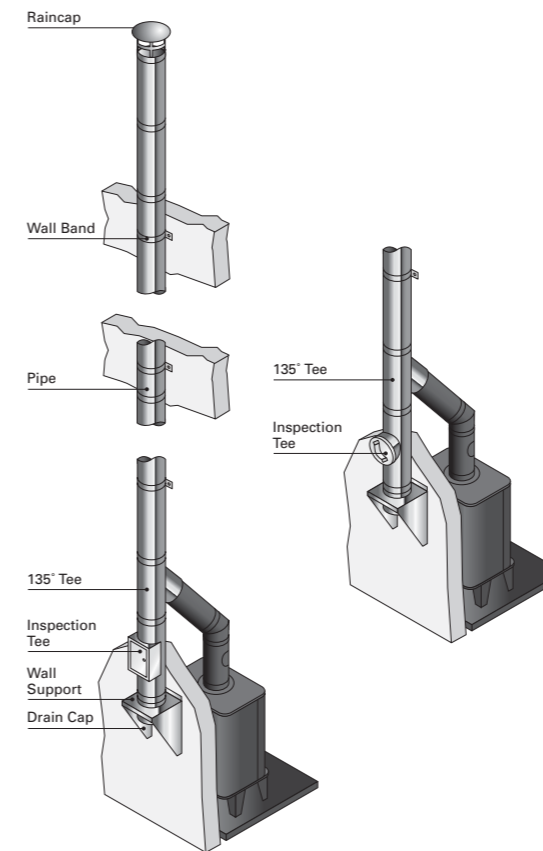

Typical Installations

- Gas or oil burning appliances.
- Maximum operating temperature of 450°C
- Minimum distance to combustible material 50mm

- Solid fuel burning appliances.
- Maximum operating temperature of 450°C
- Minimum distance to combustible material 50mm

Refer to load bearing table on page 15 for full details of maximum loadings.

Wall brackets and roof brackets are not load bearing and give lateral support only. Wall brackets should be fitted every 3m and at any offsets to ensure the system is rigidly supported.

Where the flue is free standing above the roof and its height exceeds 1.5m beyond the last support or the roof a guy wire bracket must be used, and every 1.5m thereafter. Alternatively, a height of up to 4m can be achieved unsupported with the use of an extended locking band at the joint immediately below and every joint above the roof level.

External installations

- Twin wall ICS 25mm

Covered by designations:
EN 1856-1 T200 P1 W V2 L50050 O00

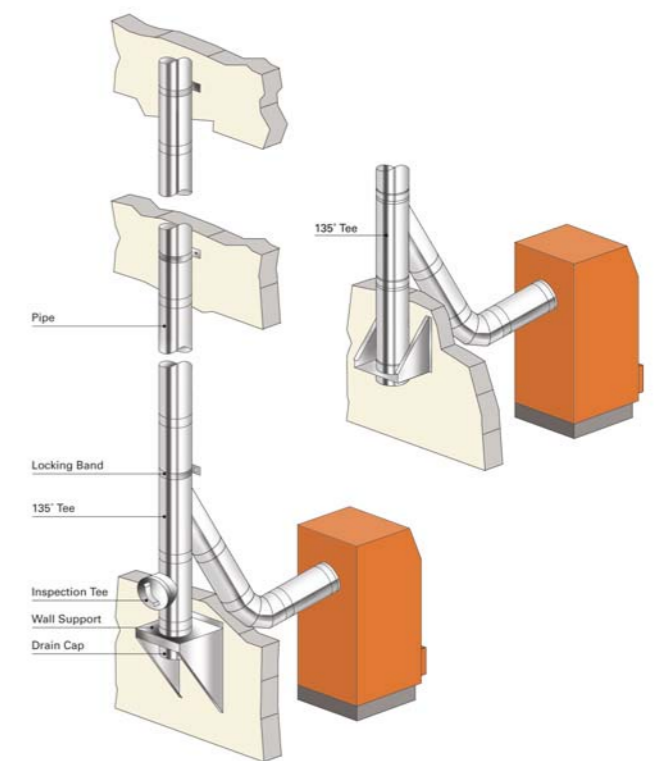

Typical Installations

- Condensing and semi-condensing appliances.
- Maximum operating temperature of 200°C
- Minimum distance to combustible material 00mm

