

TT44 SERIES TECHNICAL SPECIFICATIONS

TT44

Combustion chamber W/D: 324/231 Weight in kg: 113

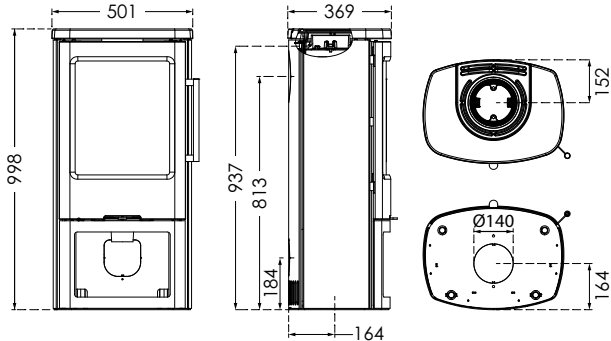

TT44S

Combustion chamber W/D: 324/231 Weight in kg: 147

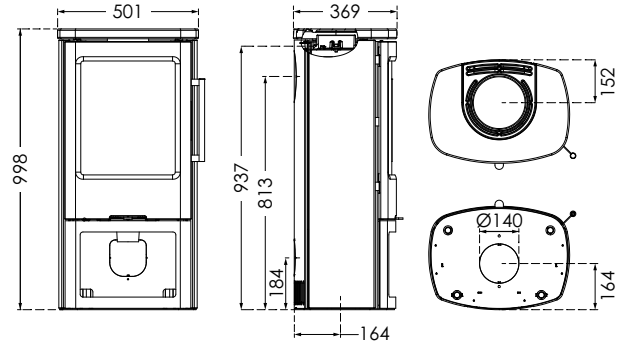

DISTANCE TO COMBUSTIBLE MATERIAL

TT44/TT44S

WITH UNINSULATED FLUE PIPE

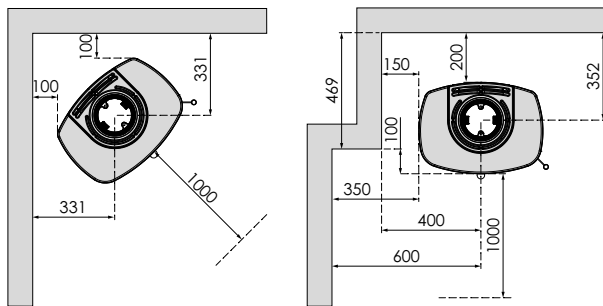

WITH INSULATED FLUE PIPE

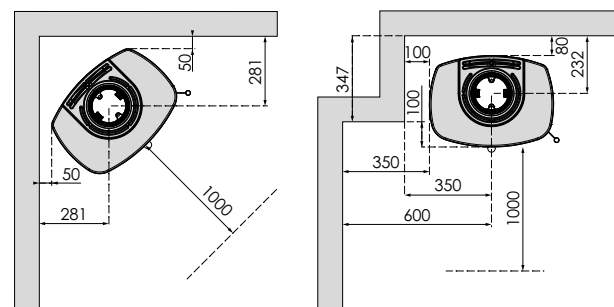

In order to avoid discolouration of painted and treated surfaces, TernaTech recommends the same distance from flammable materials as for non-flammable materials. This distance increases the convection itself around the stove and also eases cleaning. All distances relate solely to the distance of the stove from flammable materials. No account has been taken of national requirements for the use of stove flues or their distance from flammable materials.

TT44 SERIES TECHNICAL SPECIFICATIONS

TT44G

Combustion chamber W/D: 324/231 Weight in kg: 113

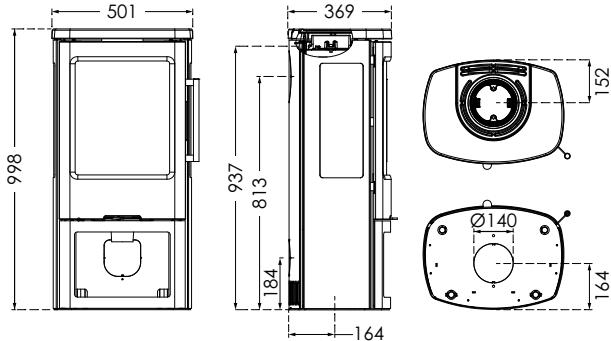

DISTANCE TO COMBUSTIBLE MATERIAL

TT44G

WITH UNINSULATED FLUE PIPE

WITH INSULATED FLUE PIPE

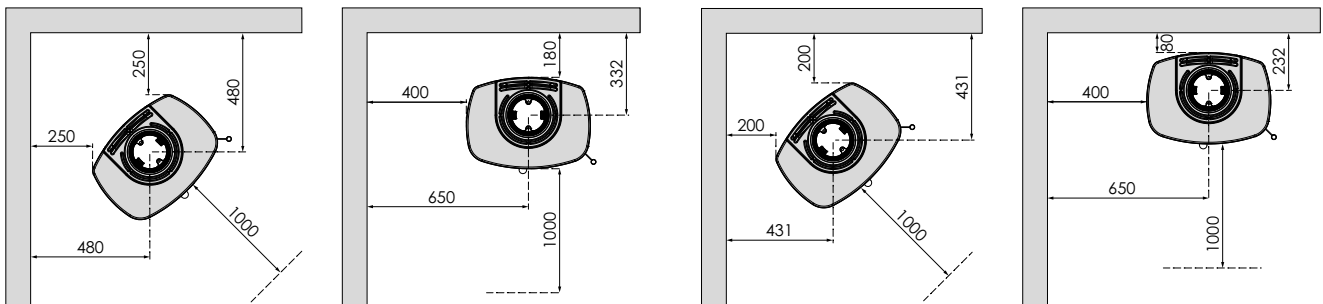

In order to avoid discolouration of painted and treated surfaces, TermaTech recommends the same distance from flammable materials as for non-flammable materials. This distance increases the convection itself around the stove and also eases cleaning. All distances relate solely to the distance of the stove from flammable materials. No account has been taken of national requirements for the use of stove flues or their distance from flammable materials.